

BLACK-STONE PATCH PANEL PRODUCT OVERVIEW

The 19-inch patch panels from BLACK-STONE not only offer exceptional performance and reliability in a high-density, shielded modular solution, but they also come with a lifetime warranty. Outlets can be effortlessly snapped into position and the durable grounding tabs ensure each outlet is adequately grounded, eliminating the need for secondary grounding procedures.

This design feature greatly reduces the overall installation time. With the added confidence of a lifetime warranty, you can trust in the enduring quality and performance of BLACK-STONE's patch panels.

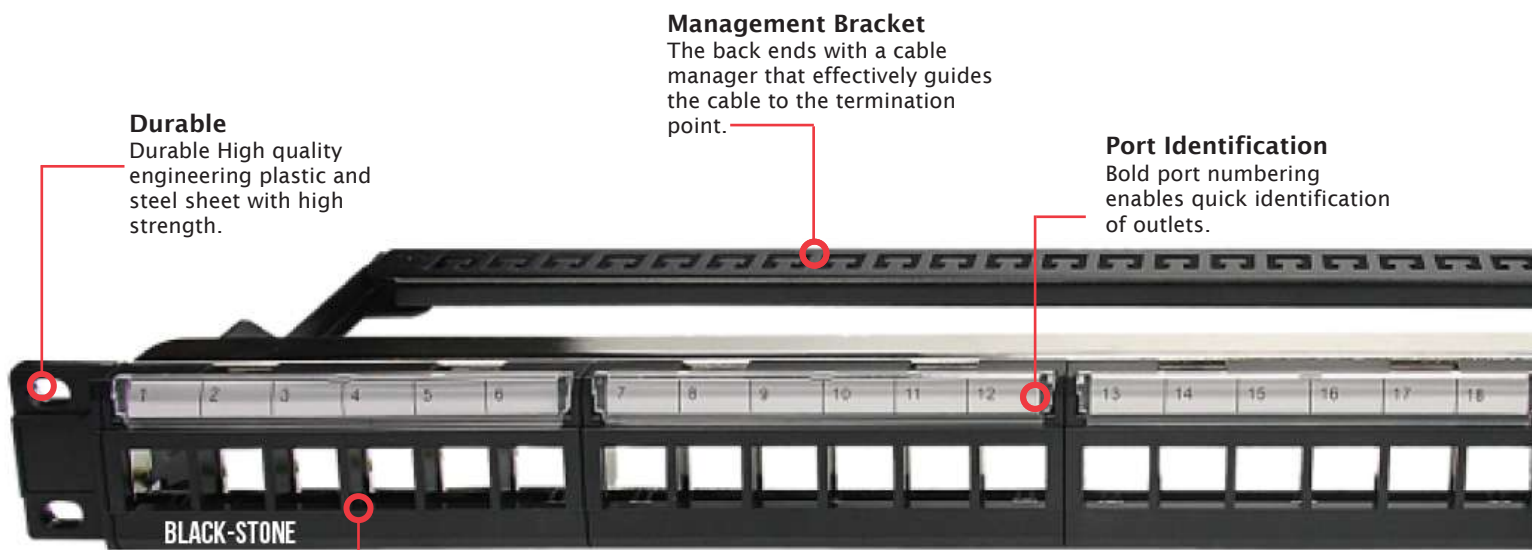

Installation Friendly
Individual modules snap into place, providing integrated grounding without additional steps.

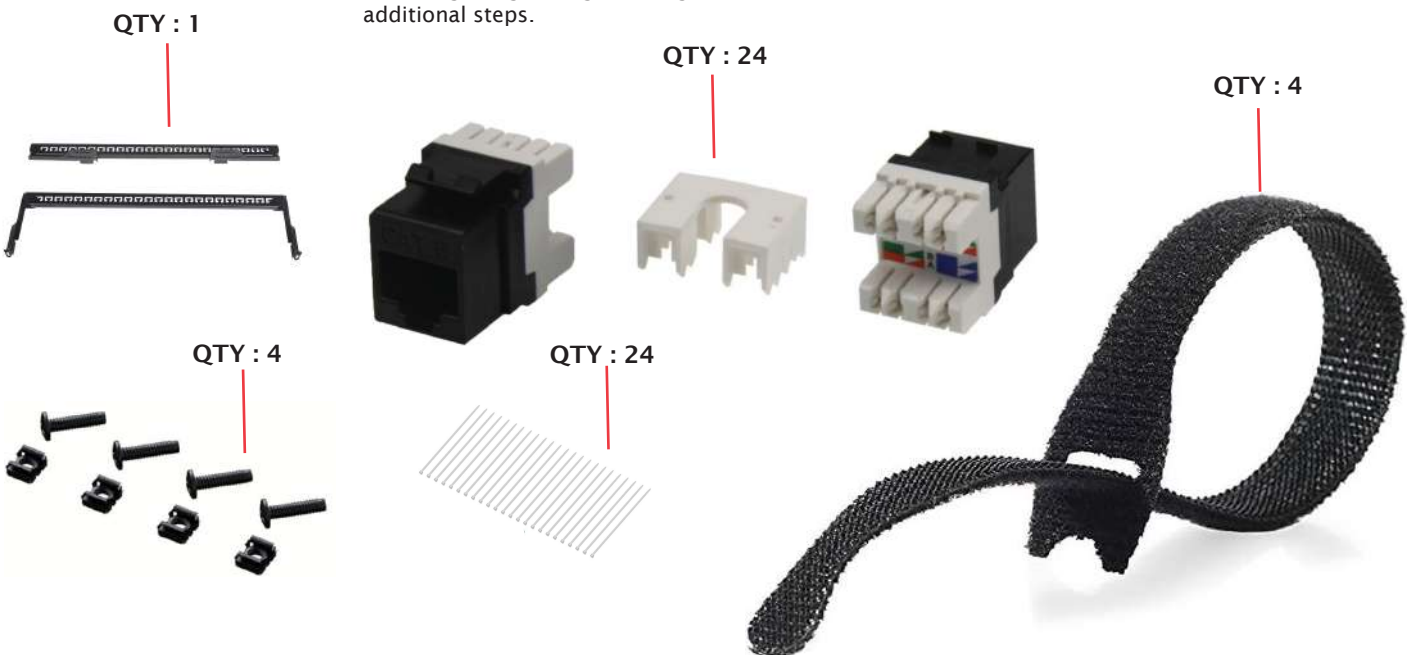

BLACK-STONE CAT6 UTP 24-PORT PATCH PANEL

24 KEYSTONE JACK INCLUDED - FULLY LOADED



PART NUMBER: BSPPM60024500

DISCRIPTION

Boost your network performance and adapt to changes effortlessly with our Rack-Mount Blackstone Patch Panel. Ideal for networks and data center applications, this patch panel facilitates easy and organized cable management by consolidating all cables in a single location.

FEATURES

- Unique exterior design, simple and compact with beautiful appearance.
- High quality engineering plastic and steel sheet with high strength.
- Ergonomic design, convenient module snap-in installation.
- Consistency black surface with any other equipment.
- Be compatible with various performance modules.
- Solid and easy installation design saves installation and operation costs.
- Be compatible with 19-inch equipment racks, cabinets, and wall mount shelf.
- All ports are large front-end marked, easier use for operation.
- The back ends with a cable manager that effectively guides the cable to the termination point.

SPECIFICATION

Patch panels shall meet or exceed the requirements for Category 6 described in ANSI/TIA-568.2-D as well as the Class E requirements described in ISO/IEC-11801.

The panels shall feature mounting standoffs for cable management bars, and front write-on labeling. The panels shall be made of 16-gauge steel, and shall have a black painted finish with white silk-screening.

The plastic elements shall be fire-retardant with a UL flammability rating of 94V-0. Panels shall be offered in 24- and 48-port configurations. Panels shall have the ability to allow for single port replacement of connectors.

DESIGN CONSIDERATIONS

- Mounts on 19-inch equipment racks
- Panel offered in 24- or 48-port configurations
- One cable management bar included per panel

Black-stone

STANDARDS COMPLIANCE

- ANSI/TIA-568.2-D
- ISO/IEC 11801
- ANSI/TIA-1096-A (formerly FCC Part 68) cULus Listed
- IEEE 802.3at (Type 1) Power over Ethernet (PoE) applications up to 15.4 watts
- IEEE 802.3at (Type 2) Power over Ethernet (PoE+) applications up to 30 watts
- IEEE 802.3bt (Type 3) Power over Ethernet (PoE+) applications up to 60 watts
- IEEE 802.3bt (Type 4) Power over Ethernet (PoE+) applications up to 100 watts
- Cisco Universal Power Over Ethernet (UPOE) applications up to 60 watts
- Power over HDBaseTTM (POH) applications up to 100 watts

ELECTRONIC FILES

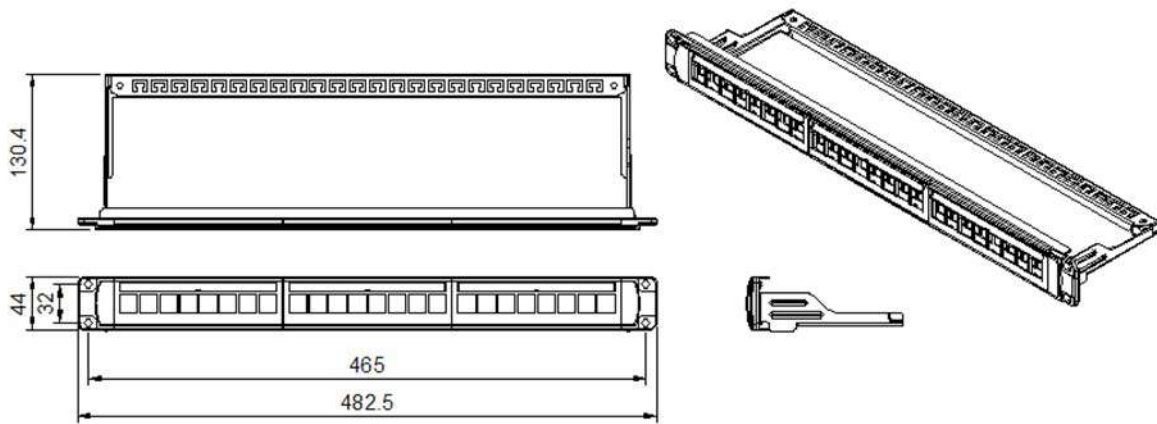

Performance Specification

Dimensions	19" x 1.75"
Capacity	24- and 48-port
Materials	16-gauge steel, painted black; PCB and plastic components.

Order information

Part No.	BSPPM60024500
Description	24-port patch panel fully loaded
Color	Black
Inner box	1 pcs
Carton	10 pcs
Carton measurement	53cm x 31cm x 23cm
Weight	12 KG

Included Parts

4 Screws (10x32); 4 Screws (12x24); 1 Printable Label; 2 Velcro Straps; 2 Rear Cable Management Bracket, 1 Installation Guide, 1 kit Termination, 24 keystone jack

Black-stone Keystone Jack

Cat6 RJ45, Unshielded, Dust Cap, PoE/
PoE+ Compliant, TAA, CE BLACK

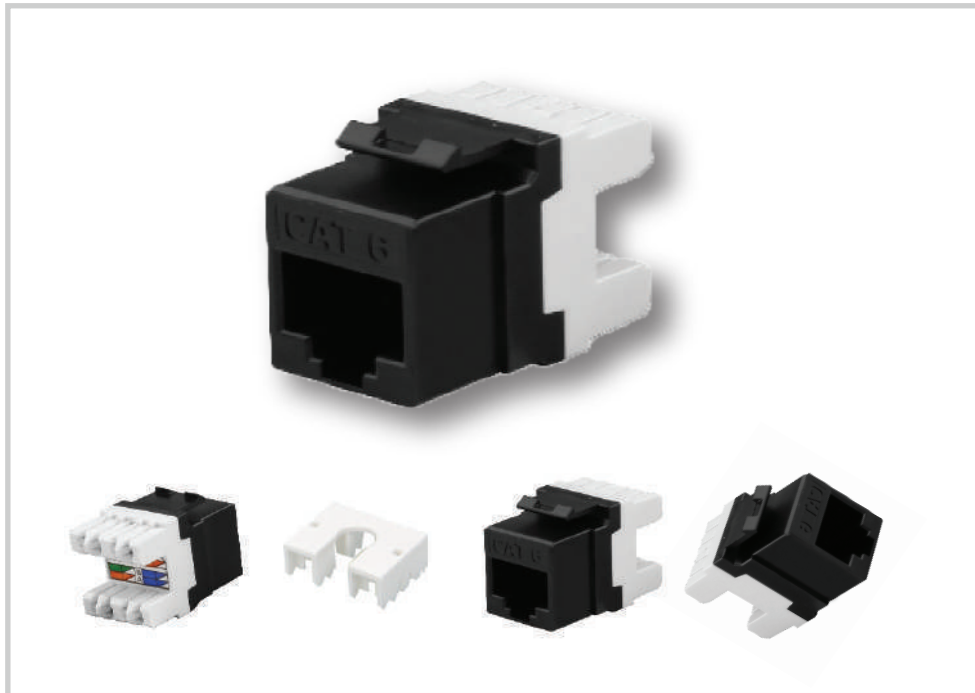

PART NUMBER: BSK-JB8000500-BL

RJ45 keystone jack lets you terminate your Cat6a/6/5e network patch cable without using a punch down tool

Features

Keystone Jack Strengthens Your High-Speed Cat6 Network Terminate your network patch cable without the time, effort and expense of a punch down tool. Ideal for Cat6 premise wiring, the RJ45 keystone jack snaps into wall plates, patch panels and surface-mount boxes and works with all shielded Cat6a cables. punch down connection is compatible with 22–24 AWG solid wire cabling. A dust cap protects the jack from dust and other contaminants when not in use.

Specifically Designed for Use in Surveillance, VoIP and Other PoE+ Applications To maximize performance with PoE (Power over Ethernet) applications, this keystone jack is specifically designed to prevent spark gap erosion that degrades the plug and jack contacts over time and can negatively influence data and/or power transmission capabilities. Connecting PoE devices saves you the expense and effort of purchasing, connecting and installing individual power supplies for each device.

Heavy Shielding Protects Your Network Data from Destructive Line Noise The fully shielded protective metal housing helps fight against EMI/RFI line noise that interferes with your network signal and can distort or destroy data.

TAA-Compliant, CE

Highlights

- RJ45 termination is quick and easy with no punch down tools required.
- Supports PoE+ to save you expense and effort of powering PoE devices individually.
- Specially designed to prevent spark-gap erosion that can affect transmission.
- Disperses EMI/RFI line noise that can destroy data and affect equipment performance.
- Includes dust cap to protect end from dust and debris when not in use.

Applications

- Connect a Cat6 network with PoE+ devices mounted in areas that are difficult to reach or have no electrical outlets.
- Set up indoor digital signage in offices, hotels, restaurants, bars, bus stations and airports.

Package Includes

BSK-JB8000500-BL, Keystone Jack
Cat6, Unshielded, TAA Dust cap
Quick Start Guide

Keystone Jack

Specifications

OVERVIEW	
Part number	BSK-JB8000500-BL
Product Type	Tool
Technology	Cat6
PHYSICAL	
Color	Silver; White
Connector Color	Silver; White
Housing Color	White; Gray
Shipping Dimensions (hwd / in.)	L 21"x W 12.3" x H 9.21"
Shipping Dimensions (hwd / cm)	L 53.5 cm x W 31.3cm x H 23.4cm
Shipping Weight (lbs.)	16.60lbs
Shipping Weight (kg)	7.60KG
Unit Dimensions (hwd / in.)	0.760 x 0.860 x 1.350
Unit Dimensions (hwd / cm)	1.92 x 2.19 x 3.43
ENVIRONMENTAL	
Operating Temperature Range	14° to 140°F (-10° to 60°C)
Storage Temperature Range	-40° to 154°F (-40° to 68°C)
Relative Humidity	10% to 90% RH, Non-Condensing
CONNECTIONS	
Number of Ports	1
Side A - Connector 1	RJ45 (FEMALE)
Side B - Connector 1	110 IDC
PoE Type	Type 4 High-Power (100W, IEEE 802.3bt)
STANDARDS & COMPLIANCE	
Product Compliance	(TT568A/T568B)
WARRANTY & SUPPORT	
Product Warranty Period (Worldwide)	Lifetime limited warranty

- Unshielded module colors to choose from :

PN:BSPPM60024500-A

COLOR : BLACK 

