

Black-stone Keystone Jack

Cat8 RJ45, Shielded, Dust Cap Tool less,
PoE/PoE+ Compliant, TAA, CE



PART NUMBER: BSKJS18106-A

Features

Keystone Jack Strengthens Your High-Speed CAT6A Network fast Installation with Special Punch Tool or Crimping Tool. Ideal for Cat8 premise wiring, the RJ45 keystone jack snaps into wall plates, patch panels and surface-mount boxes and works with all shielded Cat6a cables. Compatible with 22-24 AWG solid wire cabling. A dust cap protects the jack from dust and other contaminants when not in use.

Specifically Designed for Use in Surveillance, VoIP and Other PoE+ Applications To maximize performance with PoE (Power over Ethernet) applications, this keystone jack is specifically designed to prevent spark gap erosion that degrades the plug and jack contacts over time and can negatively influence data and/or power transmission capabilities. Connecting PoE devices saves you the expense and effort of purchasing, connect-ing and installing individual power supplies for each device.

Heavy Shielding Protects Your Network Data from Destructive Line Noise The fully shielded protective metal housing helps fight against EMI/RFI line noise that interferes with your network signal and can distort or destroy data.

TAA-Compliant, CE

Highlights

- RJ45 fast Installation with Special Punch Tool or Crimping Tool.
- Supports PoE+ to save you expense and effort of powering PoE devices individually.
- Specially designed to prevent spark-gap erosion that can affect transmission.
- Dispels EMI/RFI line noise that can destroy data and affect equipment performance.
- Includes dust cap to protect end from dust and debris when not in use.

Applications

- Connect a Cat8 network with PoE+ devices mounted in areas that are difficult to reach or have no electrical outlets.
- Set up indoor digital signage in offices, hotels, restaurants, bars, bus stations and airports.

Package Includes

BSKJS18106-A Keystone Jack Cat8
Shielded,
TAA Dust cap
Quick Start Guide

Keystone Jack

Specifications

OVERVIEW	
Part number	BSKJS18106-A
Product Type	Tool
Technology	Cat8
PHYSICAL	
Color	Silver
Connector Color	Silver
Housing Color	White; Gray
Shipping Dimensions (hwd / in.)	L 21cm x W 12.3cm x H 9.21cm
Shipping Dimensions (hwd / cm)	L 53.5 cm x W 31.3cm x H 23.4cm
Shipping Weight (lbs.)	16.60KG
Shipping Weight (kg)	7.60KG
Unit Dimensions (hwd / in.)	0.760 x 0.860 x 1.350
Unit Dimensions (hwd / cm)	1.92 x 2.19 x 3.43
ENVIRONMENTAL	
Operating Temperature Range	14° to 140°F (-10° to 60°C)
Storage Temperature Range	-40° to 154°F (-40° to 68°C)
Relative Humidity	10% to 90% RH, Non-Condensing
CONNECTIONS	
Number of Ports	1
Side A - Connector 1	RJ45 (FEMALE)
Side B - Connector 1	110 IDC
PoE Type	Type 4 High-Power (100W, IEEE 802.3bt)
STANDARDS & COMPLIANCE	
Product Compliance	(TT568A/T568B)
WARRANTY & SUPPORT	
Product Warranty Period (Worldwide)	Lifetime limited warranty



BLACKSTONE Keystone Jack Installation Guide

JACK PIN DESIGNATION	TIA/EIA T568A	TIA/EIA T568B
	1 White/Green	White/Orange
	2 Green	Orange
	3 White/Orange	White/Green
	6 Orange	Green
	4 Blue	Blue
	5 White/Blue	White/Blue
	7 White/Brown	White/Brown
8 Brown	Brown	

1. Prepare the Cable:

Strip approximately 40mm of the cable jacket, leaving approximately 15mm of foil shielding intact. Separate the wires into four pairs for proper arrangement.

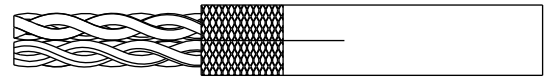

2. Position the Wires

Insert the wires through the plastic cap and lay them into the designated slots following the wiring diagram printed on the cap. Trim the wires flush with the cap, ensuring the wire tips protrude no more than 0.1 mm for precise termination.

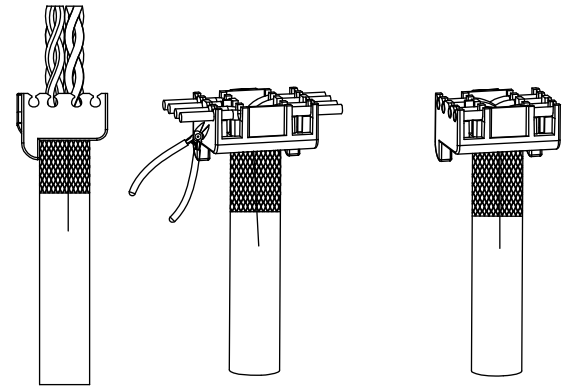

3. Align and Secure the Cap

Match the direction of the arrows on both the cap and the IDC connector. Press the cap firmly into the IDC, ensuring that the wires are seated deeper than the tiny teeth inside the IDC slots for a secure connection. Let me know if you'd like further refine-

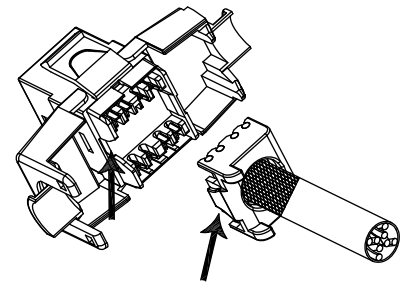

4. Lock the Outer Cap

Close the outer cap by pushing down on both sides until it clicks securely in place.

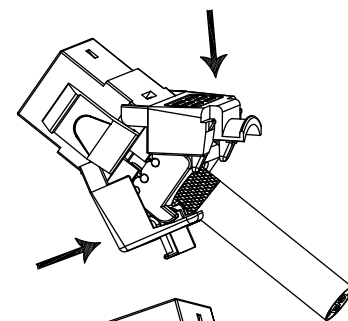

5. Ground the Connection

Connect the drain wire to the shielded shell housing for proper grounding. Fasten the cable tie to secure the assembly and complete the installation process.

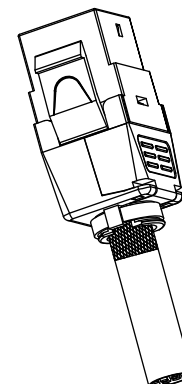

SCAN ME

Black-stone