

BLACK-STONE UTP 24-PORT EMPTY PATCH PANEL



DISCRIPTION

Boost your network performance and adapt to changes effortlessly with our Rack-Mount Blackstone Patch Panel. Empty 24-port patch panel matches the installation of different kinds of modular jacks, suitable for interaction and termination of horizontal cabling between devices, equipment and centralized points.

FEATURES

- Unique exterior design, simple and compact with beautiful appearance.
- High quality engineering plastic and steel sheet with high strength.
- Ergonomic design, convenient module snap-in installation.
- Consistency black surface with any other equipment.
- Be compatible with various performance modules.
- Solid and easy installation design saves installation and operation costs.
- Be compatible with 19-inch equipment racks, cabinets, and wall mount shelf.
- All ports are large front-end marked, easier use for operation.
- The back ends with a cable manager that effectively guides the cable to the termination point.

SPECIFICATION

Patch panels shall meet or exceed the channel requirements for Cat 6A described in ANSI/TIA-568.2-D and ISO 11801, and shall be packed with the appropriate number of Cat 6A connectors.

Connectors shall feature both T568A and T568B wiring configurations, mounting standoffs for cable management bars, and front write-on labeling. Panels shall be made of 16-gauge steel and shall have a black painted finish with white silk-screening.

The plastic elements shall be fire retardant with a UL flammability rating of 94V-0. Panels shall be offered in 24- and 48-port configurations. Panel shall have the ability to allow for single port replacement of inoperative ports. for single port replacement of connectors.

DESIGN CONSIDERATIONS

- Mounts on 19-inch equipment racks
- Panel offered in 24- or 48-port configurations
- One cable management bar included per panel

Black-stone

STANDARDS COMPLIANCE

- ANSI/TIA-568.2-D
- ISO 11801 Class EA
- cULus Listed
- IEEE 802.3bt PoE Type 1, 2, 3, 4 (90 watts max)
- Cisco UPOE, UPOE+ (90 watts max)
- Power over HDBaseT™ PoH (95 watts max)

ELECTRONIC FILES

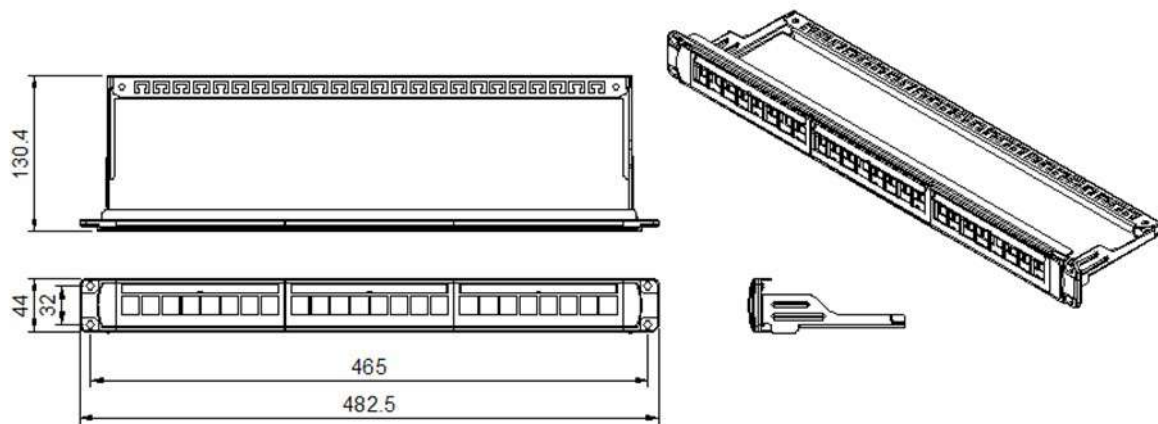

Performance Specification

Dimensions	19" × 1.75"
Capacity	24- and 48-port
Materials	16-gauge steel, painted black; PCB and plastic components.

Order information

Part No.	BSPPM600
Description	24 ports empty patch panel
Color	Black
Inner box	1 pcs
Carton	10 pcs
Carton measurement	53cm × 31cm × 23cm
Weight	8 KG

Included Parts

4 Screws (10x32); 4 Screws (12x24); 1 Printable Label; 2 Velcro Straps; 2 Rear Cable Management Bracket, 1 Installation Guide, 1 kit Termination.