

Black-stone Horizontal Back Cable Management

DISCRIPTION

Blackstone horizontal back cable management Be compatible with 19-inch equipment rack, cabinets, and wall mount shelf, suitable for interaction and termination of horizon-tal cabling between devices, equipment and centralized points.



FEATURES

- Made of high quality ABS plastic to avoid scratching, with detachable surface faceplate design.
- Accomplish a clean and beautiful cabling system with simple,flexible, effective and safe feature.
- Unique exterior design, simple, compact and beautiful.
- Black appearance enables its combination of any other equipment in data center.

ELECTRONIC FILES

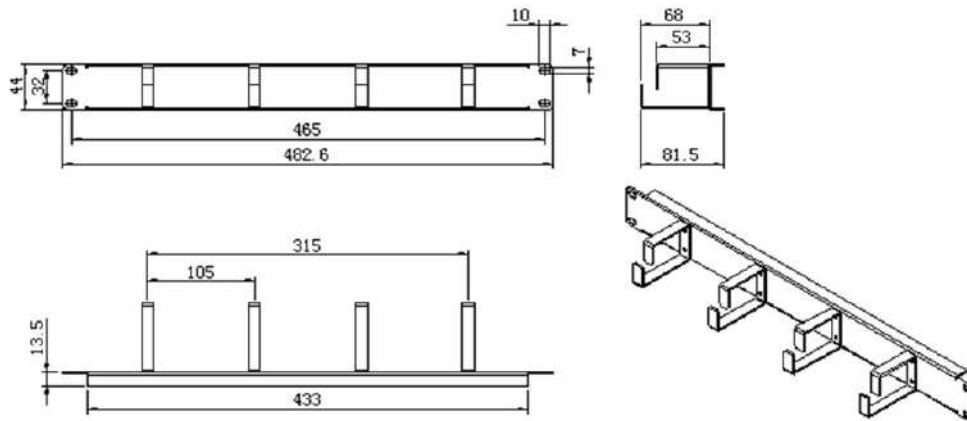

Order information

Part No.	BSABP1465636
Description	Black-stone Horizontal Back panel 1U
Color	Black
Inner box	1PCS
Carton	20pcs
Carton measurement	31CM*53CM*22CM
Weight	15KG